

# Installation Instructions

## Trailer Hitch Kit Part No. 5049751

Fits Simplicity: 1694454  
Fits Snapper: 5091000  
1694455  
5091001  
1694460

This kit will install a trailer hitch on the rear bumper.

### Kit Contents:

Part No.	Qty.	Description
2849754	1	Trailer Hitch Plate
2849791	1	Support Plate
5049753	1	Warning Decal
7091497	2	3/8-16 x 1-1/2" Bolt
7091297	2	3/8-16 Hex Nylon Lock Nut
7090122	4	3/8" SAE Washer

### **⚠** WARNING

Before beginning any service work turn off the PTO, set the parking brake, turn off the ignition, and disconnect the spark plug wire(s).

### Tools Required:

- (1) Drill & 7/16" drill bit
- (1) 3/8" drive ratchet & 9/16" socket
- (1) 9/16" combination wrench
- (1) Prick punch & hammer
- (1) Marker or pencil
- (1) Vise-Grip clamp or C-clamp

## INSTALLATION

1. Locate the holes on the bottom edge of the bumper. If the bumper does not have pre-existing holes, continue with Step 2. If the bumper has holes, skip to Step 4.
2. Place the hitch plate (A, Figure 1) on the bottom edge of the bumper. Center the plate side-to-side, and flush with the inside edge. Clamp in place.
3. Using the holes in the hitch plate as a template, mark the bumper with either a prick punch or marker/pencil. Remove the mounting plate and drill 7/16" holes through the bumper.
4. Install the tow hitch plate and support plate (C & D Figure 2) on the bumper and install the 3/8-16 x 1-1/2" bolts, washers and flange nuts (A,B & E). Tighten hardware securely.
5. Clean the outside surface of the bumper, between the hitch plate and rear shield with a mild cleaning solution to remove any dirt or grease and dry. Apply the warning decal as shown in Figure 3.

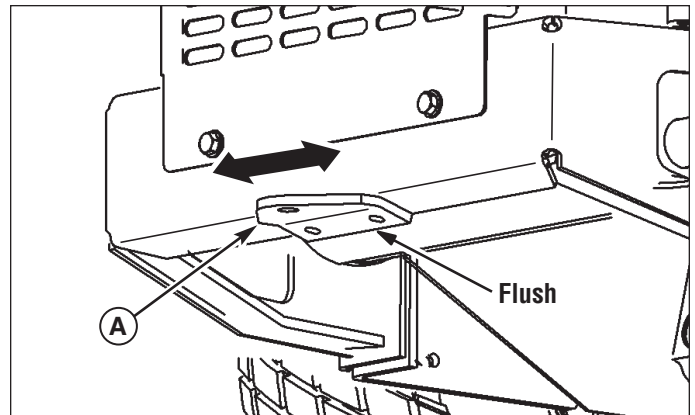

Figure 1. Clamp Hitch Plate In Place

A. Hitch Plate

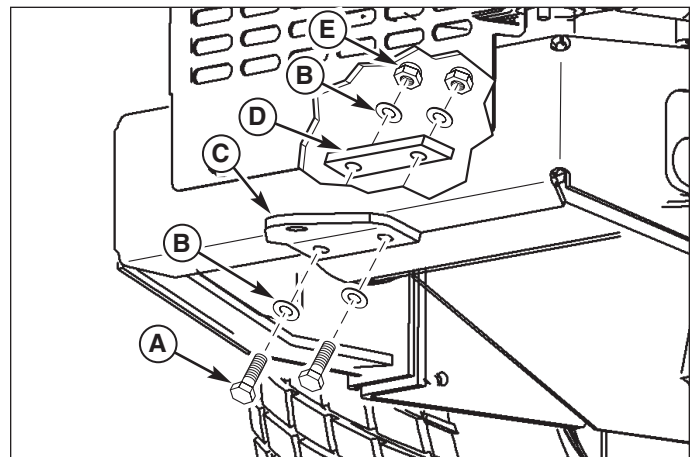

Figure 2. Install Hitch Plate

A. 3/8-16 x 1-1/2" Bolts

B. 3/8" SAE Washers

C. Hitch Plate

D. Support Plate

E. 3/8-16 Nylon Lock Nuts

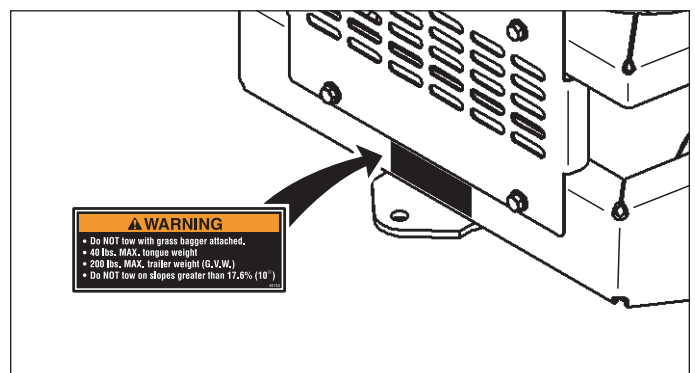

Figure 3. Install Warning Decal